

Fișă tehnică produs

Specificatii



Variator de viteza - ATV930 - 1,5kw - 400/480V - cu unitate de franare - IP21

ATV930U15N4

Principale

gama de produse	Altivar Process ATV900
aplicatie specifica produsului	Process for industrial
Tip produs sau componenta	Variator de viteza
varianta	With braking chopper Standard version
aplicatie a dispozitivului	Industrial application
destinatie produs	Motoare asincrone Motoare sincrone
numar de fazein retea	3 faze
mod de montare	Wall mount
curent la iesire continuu	4 A la 4 kHz pentru serviciu normal 2,2 A la 4 kHz pentru pentru sarcini grele
Port protocol de comunicatie	Modbus TCP Ethernet/IP Serial Modbus
option module	Slot A modul de comunicare pentru Profibus DP V1 Slot A modul de comunicare pentru PROFINET Slot A modul de comunicare pentru DeviceNet Slot A modul de comunicare pentru EtherCAT Slot A modul de comunicare pentru rețea CANopen RJ45 Slot A modul de comunicare pentru CANopen SUB-D 9 Slot A modul de comunicare pentru CANopen screw terminals Slot A/slot B/slot C digital and analog I/O extension module Slot A/slot B/slot C output relay extension module Slot B 5/12 V digital encoder interface module Slot B analog encoder interface module Slot B resolver encoder interface module modul de comunicare pentru Ethernet Powerlink
[Us] tensiune nominala de alimentare	380...480 V - 15...10 %
[Us] tensiune de alimentare nominala	380...480 V
Relative symmetric mains voltage tolerance	10 %
Relative symmetric network frequency tolerance	5 %
curent nominal de iesire	4,0 A
putere motor kW	1,5 kW pentru serviciu normal 0,75 kW pentru pentru sarcini grele
filtru EMC	Integrat With EMC plate option
grad de protectie IP	IP21
grad de protectie	UL tip 1

Suplimentare

conexiune electrica	Control borna cu surub 0.5...1.5 mm ² AWG 20...AWG 16 Line side borna cu surub 2.5...6 mm ² AWG 14...AWG 10 Motor borna cu surub 2.5...6 mm ² AWG 14...AWG 10 DC bus borna cu surub 2.5...6 mm ² AWG 14...AWG 10
rata de transmisie	10/100 Mbit/s pentru Ethernet IP/Modbus TCP 4.8, 9.6, 19.2, 38.4 kbit/s pentru serial Modbus
mod de schimb	Half duplex, full duplex, autonegociere Ethernet IP/Modbus TCP
format data	8 biti, configurabil impar, par sau fara paritate pentru serial Modbus
tip de polarizare	Fara impedanta pentru serial Modbus
numar de adrese	1...247 pentru serial Modbus
alimentare	External supply for digital inputs 24 V c.c. (19...30 V), <1,25 mA, tip de protecție: protecție la suprasarcina si scurtcircuit Sursă internă pentru potențiometrul de referință (1 la 10 kOhm) 10.5 V c.c. +/- 5 %, <10 mA, tip de protecție: protecție la suprasarcina si scurtcircuit Internal supply for digital inputs and STO 24 V c.c. (21...27 V), <200 mA, tip de protecție: protecție la suprasarcina si scurtcircuit
semnalizare locala	Local diagnostic: 3 LED (mono/dual colour) Embedded communication status: 5 LED (dual colour) Communication module status: 2 LED (dual colour) Prezenta tensiune: 1 LED (rosu)
compatibilitate intrare	DI1...DI8 intrare directă nivel 1 PLC conformitate cu IEC 61131-2 DI7, DI8 pulse input nivel 1 PLC conformitate cu IEC 65A-68 STOA, STOB intrare directă nivel 1 PLC conformitate cu IEC 61131-2
logica de intrare discreta	Logica pozitiva (sursa) (DI1...DI8), < 5 V (stare 0), > 11 V (stare 1) Logica negativa (derivatie) (DI1...DI8), > 16 V (stare 0), < 10 V (stare 1) Logica pozitiva (sursa) (DI7, DI8), < 0.6 V (stare 0), > 2.5 V (stare 1) Logica pozitiva (sursa) (STOA, STOB), < 5 V (stare 0), > 11 V (stare 1)
perioada de esantionare	2 ms +/- 0.5 ms (DI1...DI8) - intrare directă 5 ms +/- 1 ms (DI7, DI8) - pulse input 1 ms +/- 1 ms (AI1, AI2, AI3) - intrare analogică 5 ms +/- 1 ms (AQ1, AQ2) - ieșire analogică
precizie	+/- 0.6 % AI1, AI2, AI3 pentru o variație a temperaturii 60 °C intrare analogică +/- 1 % AQ1, AQ2 pentru o variație a temperaturii 60 °C ieșire analogică
eroare de liniaritate	AI1, AI2, AI3 +/- 0.15 % din valoarea maximă pentru intrare analogică AQ1, AQ2 +/- 0,2 % pentru iesire analogica
tim de reimprospatare	Relay output (R1, R2, R3) 5 ms (+/- 0.5 ms)
izolatie	Intre alimentare si bornele de control
numar intrare discreta	10
tip de intrare discreta	DI1...DI8 programabile, 24 V c.c. (<= 30 V), impedanță: 3.5 kOhm DI7, DI8 programmable as pulse input 0...30 kHz, 24 V c.c. (<= 30 V) STOA, STOB cuplu de siguranță, 24 V c.c. (<= 30 V), impedanță: > 2.2 kOhm
numar iesire discreta	2
tip de iesire discreta	Ieșire logică DQ+ 0...1 kHz <= 30 V c.c. 100 mA Programmable as pulse output DQ+ 0...30 kHz <= 30 V c.c. 20 mA Ieșire logică DQ- 0...1 kHz <= 30 V c.c. 100 mA
numarul intrarii analogice	3
tip de intrare analogica	AI1, AI2, AI3 tensiune configurabilă soft 0...10 V c.c., impedanță: 30 kOhm, rezoluție 12 biti AI1, AI2, AI3 curent configurabil soft 0...20 mA/4...20 mA, impedanță: 250 Ohm, rezoluție 12 biti
numarul iesirii analogice	2
tip iesire analogica	Tensiune configurabilă soft AQ1, AQ2 0...10 V c.c. 470 Ohm, rezoluție 10 bits Curent configurabil soft AQ1, AQ2 0...20 mA 500 Ohm, rezoluție 10 bits
numarul iesirii releu	3

tip releu iesire	Configurable relay logic R1 releu de defect NO/NC 100000 cic Configurable relay logic R2 sequence relay nu 1000000 cic Configurable relay logic R3 sequence relay nu 1000000 cic
curent maxim de comutatie	Relay output R1 pornit rezistiv sarcina, cos phi = 1 3 A la 250 V c.a. Relay output R1 pornit rezistiv sarcina, cos phi = 1 3 A la 30 V c.c. Relay output R1 pornit inductiv sarcina, cos phi = 0,4 si stanga/dreapta = 7 ms 2 A la 250 V c.a. Relay output R1 pornit inductiv sarcina, cos phi = 0,4 si stanga/dreapta = 7 ms 2 A la 30 V c.c. Relay output R2, R3 pornit rezistiv sarcina, cos phi = 1 5 A la 250 V c.a. Relay output R2, R3 pornit rezistiv sarcina, cos phi = 1 5 A la 30 V c.c. Relay output R2, R3 pornit inductiv sarcina, cos phi = 0,4 si stanga/dreapta = 7 ms 2 A la 250 V c.a. Relay output R2, R3 pornit inductiv sarcina, cos phi = 0,4 si stanga/dreapta = 7 ms 2 A la 30 V c.c.
curentul minim de comutare	Relay output R1, R2, R3 5 mA la 24 V c.c.
logica de intrare discreta	16 preset speeds
interfata fizica	Ethernet RS 485 cu 2 fire
tipul conectorului	2 RJ45 1 RJ45
metoda de acces	Slave Modbus TCP
rata de transmisie	10, 100 Mbits 4.8 kbps 9600 bit/s 19200 bit/s
cadrul de transmisie	RTU
numarul de adrese	1...247
format date	8 biti, configurabil impar, par sau fara paritate
tip de polarizare	Fara impedanta
4 quadrant operation possible	Adevarat
profil de control al motorului asincron	Constanta de cuplu standard Mod de cuplu optim Cuplu variabil standard
profil de control al motorului sincron	Permanent magnet motor Synchronous reluctance motor
frecventa maxima de iesire	599 Hz
rampe de accelerare si decelerare	Reglabil liniar separat, de la 0,01 la 9999 s
compensare alunecare motor	Reglabil Poate fi suprimat Automat indiferent de sarcina Not available in permanent magnet motor law
frecventa de comutare	2...16 kHz reglabil 4...16 kHz cu
frecventa de comutare nominala	4 kHz
franare sau imobil	Cu injectie c.c.
Brake chopper integrated	Adevarat
curent de linie	3,0 A la 380 V (serviciu normal) 1,7 A la 380 V (pentru sarcini grele) 2,6 A la 480 V (serviciu normal) 1,5 A la 480 V (pentru sarcini grele)
Curent maxim de intrare	3,0 A
Maximum output voltage	480,0 V
putere aparenta	2,2 kVA la 480 V (serviciu normal) 1,2 kVA la 480 V (pentru sarcini grele)

curent tranzitoriu maxim	4,8 A in timpul 60 s (serviciu normal) 3,3 A in timpul 60 s (pentru sarcini grele)
frecventa retea electrica	50...60 Hz
curent de scurtcircuit prezumat I_{sc}	50 kA
Base load current at high overload	2,2 A
Base load current at low overload	4,0 A
puterea disipata in W	Convectie naturala 28 W la 380 V 4 kHz Convectie fortata 41 W la 380 V 4 kHz
cu functia de siguranta Safely Limited Speed (SLS)	Adevarat
cu functia de siguranta Safe brake management (SBC/SBT)	Adevarat
cu functia de siguranta Safe Operating Stop (SOS)	Fals
cu functia de siguranta Safe Position (SP)	Fals
cu functia de siguranta Safe programmable logic	Fals
cu functia de siguranta Safe Speed Monitor (SSM)	Fals
cu functia de siguranta Safe Stop 1 (SS1)	Adevarat
cu functia de siguranta Safe Stop 2 (SS2)	Fals
cu functia de siguranta Safe torque off (STO)	Adevarat
cu functia de siguranta Safely Limited Position (SLP)	Fals
cu functia de siguranta Safe Direction (SDI)	Fals
tip de protectie	Protectie termica motor Safe torque off motor Înterupere fază motor motor Protectie termica variator Safe torque off variator Supraincalzire variator Supracurent între fazele de ieșire și pământ variator Overload of output voltage variator Protectie la scurtcircuit variator Înterupere fază motor variator Supratensiuni pe magistrala de c.c. variator Supratensiune în linia de alimentare variator Scăderea tensiunii de alimentare variator Pierdere de fază în alimentarea liniei de alimentare variator Overspeed variator Defectarea circuitului de comandă variator
Cantitate pe set	1
latime	144 mm
inaltime	350 mm
adancime	206 mm
greutate produs	4,5 kg

Mediu

rezistenta de izolatie	> 1 MOhm 500 V c.c. pentru 1 minut la pământ
nivel de zgomot	54,5 dB conformitate cu 86/188/EEC
rezistenta la vibratii	1.5 mm vârf la vârf (f= 2...13 Hz) conforming to IEC 60068-2-6 1 gn (f= 13...200 Hz) conforming to IEC 60068-2-6
rezistenta la socuri	15 gn pentru 11 ms conformitate cu IEC 60068-2-27

caracteristica de mediu	Chemical pollution resistance class 3C3 conformitate cu IEC 60721-3-3 Dust pollution resistance class 3S3 conformitate cu IEC 60721-3-3
umiditate relativa	5...95 % fără condensare conformitate cu IEC 60068-2-3
temperatura ambientală de utilizare	-15...50 °C (fără declasare) 50...60 °C (cu)
altitudinea de funcționare	<= 1000 m fără declasare 1000...4800 m cu declasarea curentului cu 1 % pe 100 m
poziție de operare	Vertical +/- 10 grade
certificari produs	TÜV CSA UL
marcaj	CE
standarde	UL 508C IEC 61800-3 IEC 61800-5-1 IEC 61000-3-12 IEC 60721-3 IEC 61508 IEC 13849-1
THDI maxim	<48 % sarcină nominală conformitate cu IEC 61000-3-12
stil de asamblare	Incorporat
compatibilitate electromagnetica	Test de imunitate la descarcari electrostatice nivel 3 conforming to IEC 61000-4-2 Test de imunitate la frecvența radio radiată nivel 3 conforming to IEC 61000-4-3 Tranziții rapizi/test de imunitate la impulsuri de ionizare nivel 4 conforming to IEC 61000-4-4 1.2/50 μs - 8/20 μs test de imunitate la supratensiuni nivel 3 conforming to IEC 61000-4-5 Test de imunitate la radiofrecvență condusă nivel 3 conforming to IEC 61000-4-6
clasa de mediu (in timpul funcționării)	Clasa 3C3 in conformitate cu IEC 60721-3-3-3 Class 3S3 according to IEC 60721-3-3
accelerația maximă în cazul unui impact de soc (in timpul funcționării)	150 m/s ² la 11 ms
accelerația maximă sub tensiune de vibrație (in timpul funcționării)	10 m/s ² la 13...200 Hz
deformarea maximă sub sarcină vibratorie (in timpul funcționării)	1.5 mm la 2...13 Hz
Permitted relative humidity (during operation)	Class 3K5 according to EN 60721-3
volumul aerului de răcire	38 m ³ /h
categorie de supratensiune	III
bucla de reglare	Regulator PID reglabil
nivel de zgomot	54,5 dB
Grad de poluare	2
Temperatura de transport a aerului ambiental	-40...70 °C
temperatura ambientală pentru depozitare	-40...70 °C

Unitati de ambalare

Unitate de masura pentru prima forma de impachetare	PCE
Număr de produse în pachet	1
Înălțime prima forma de impachetare	31,000 cm
Latime prima forma de impachetare	19,000 cm
Lungime prima forma de impachetare	41,000 cm

Greutate colet(Lbs)	5,791 kg
Unitate de masura pentru a doua forma de impachetare	S06
Numar unitati in a doua forma de impachetare	6
Inaltime a doua forma de impachetare	75,000 cm
Latime a doua forma de impachetare	60,000 cm
Lungime a doua forma de impachetare	80,000 cm
Greutate a doua forma de impachetare	47,806 kg

Garanție contractuală

Garantie (in luni)	18
--------------------	----

Schneider Electric isi propune sa atinga nivelul Net Zero pana in 2050 prin parteneriate la nivelul lantului de aprovizionare, materiale cu impact mai redus si circularitate, prin campania „Use Better, Use Longer, Use Again” pentru a extinde durata de viata a produselor si reciclabilitatea.

[Environmental Data explicate >](#)

[Cum evaluam sustenabilitatea produselor >](#)

Amprenta de mediu

Amprenta de carbon totala pe durata de viata	1 262 kg CO2 eq.
Amprenta de carbon a fazei de fabricație [A1–A3]	82 kg CO2 eq.
Amprenta de carbon a fazei de distribuție [A4]	1 kg CO2 eq.
Amprenta de carbon a fazei de instalare [A5]	3 kg CO2 eq.
Amprenta de carbon a fazei de utilizare [B2, B3, B4, B6]	1 169 kg CO2 eq.
Amprenta de carbon a fazei de sfârșit de viață [C1–C4]	6 kg CO2 eq.

Use Better

Materiale si ambalare

Pachet cu carton reciclabil	Da
Ambalaj fara plastic	Da
Numar SCIP	4de62941-2f5a-4018-a63f-6ca03d378705
Directiva RoHS a UE	Conform Prin Scutire
Regulamentul REACH	Referinta contine SVHC peste prag

Eficienta energetica

Contributiia produs a fost evitata	Da
------------------------------------	----

Use Longer

Prelungire durata de viata

Reparare	Nu
----------	----

Use Again

Reambalare si refabricare

Potentialul de reciclabilitate, in %	77
Profil circularitate	Informatii privind sfarsitul duratei de viata
Baterie detasabila	Da
Preluare la sfarsitul duratei de viata	Da
Eticheta WEEE	 În Uniunea Europeana, produsele trebuie reciclate respectand sistemul specific de colectare a deseurilor si nu trebuie sa ajunga in pubelele de colectare a deseurilor menajere.

Dimensions Drawings

Dimensions

Right, Front and Rear View

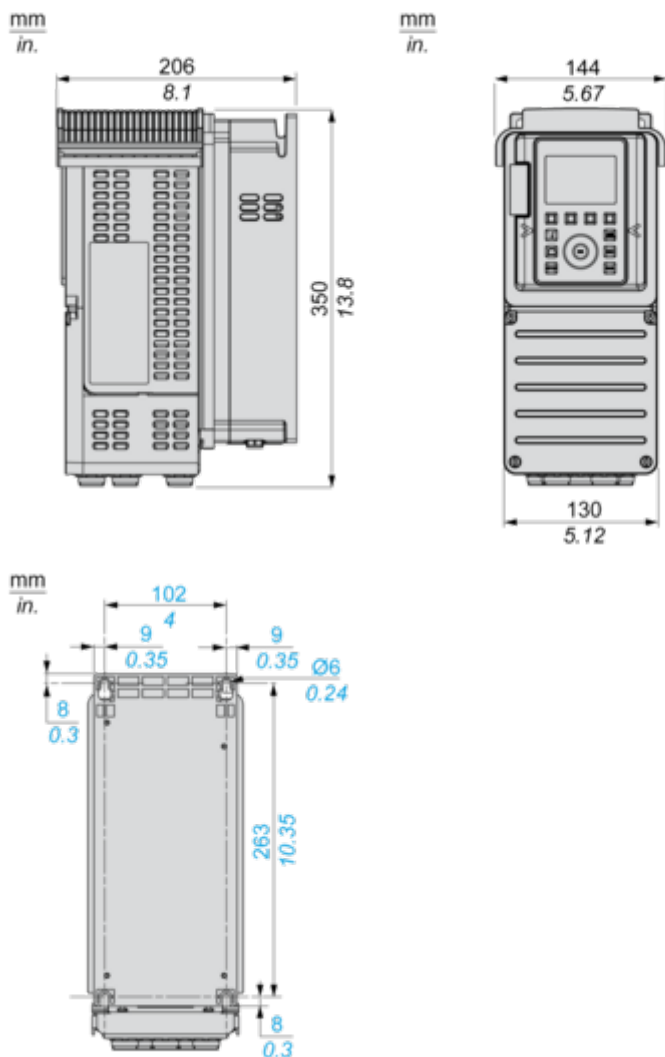

Mounting and Clearance

Clearances



X1	X2	X3
≥ 100 mm (3.94 in.)	≥ 100 mm (3.94 in.)	≥ 10 mm (0.39 in.)

- Mount the device in a vertical position ($\pm 10^\circ$). This is required for cooling the device.
- Do not mount the device close to heat sources.
- Leave sufficient free space so that the air required for cooling purposes can circulate from the bottom to the top of the drive.

Mounting Types

Mounting Type A: Individual IP21

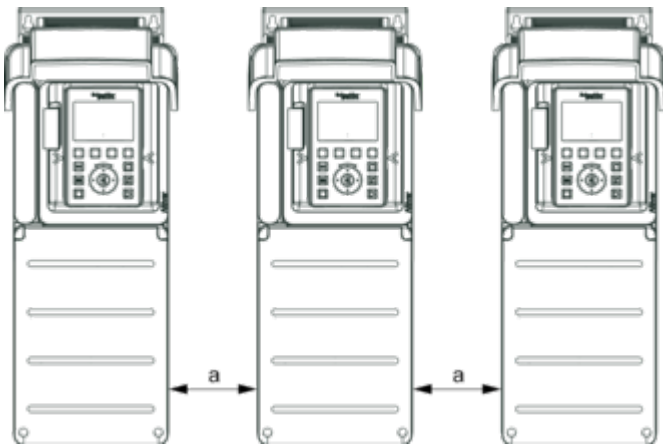

$a \geq 100 \text{ mm (3.94 in.)}$

Mounting Type B: Side by Side IP20



Mounting Type C: Individual IP20

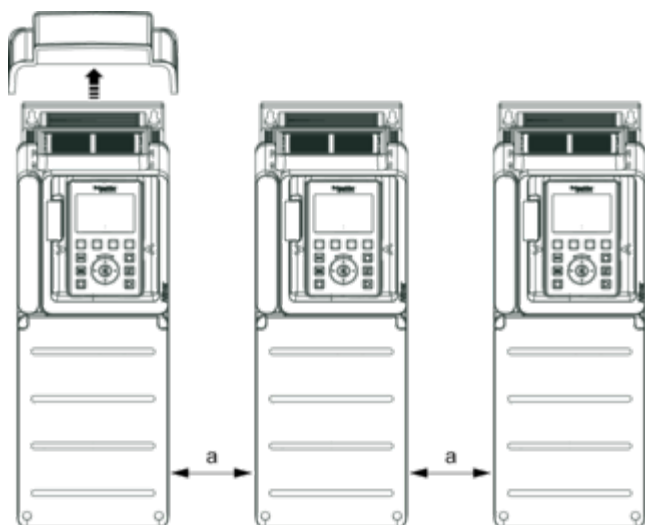

$a \geq 0$

Connections and Schema

Three-Phase Power Supply with Upstream Breaking via Line Contactor

Connection diagrams conforming to standards EN 954-1 category 1 and IEC/EN 61508 capacity SIL1, stopping category 0 in accordance with standard IEC/EN 60204-1

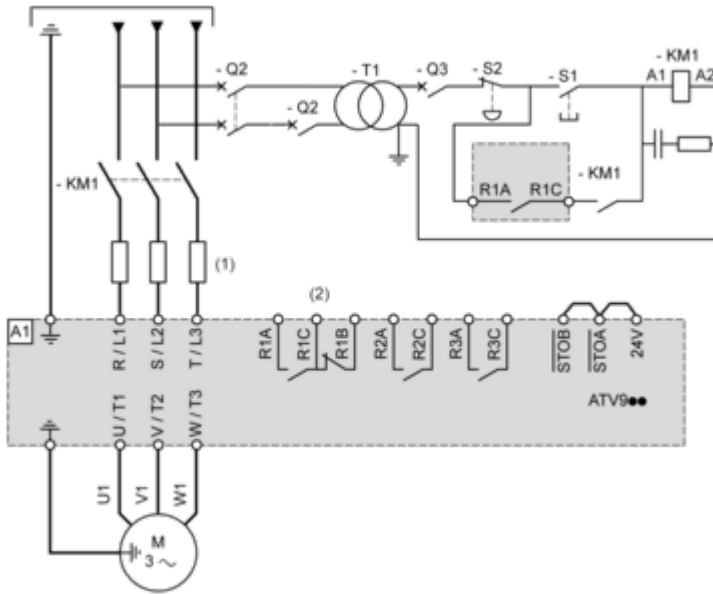

(1) Line choke if used

(2) Use relay R1 set to operating state Fault to switch Off the product once an error is detected.

A1 : Drive

KM1 : Line Contactor

Q2, Q3 : Circuit breakers

S1, S2 : Pushbuttons

T1 : Transformer for control part

Three-Phase Power Supply with Downstream Breaking via Contactor

Connection diagrams conforming to standards EN 954-1 category 1 and IEC/EN 61508 capacity SIL1, stopping category 0 in accordance with standard IEC/EN 60204-1

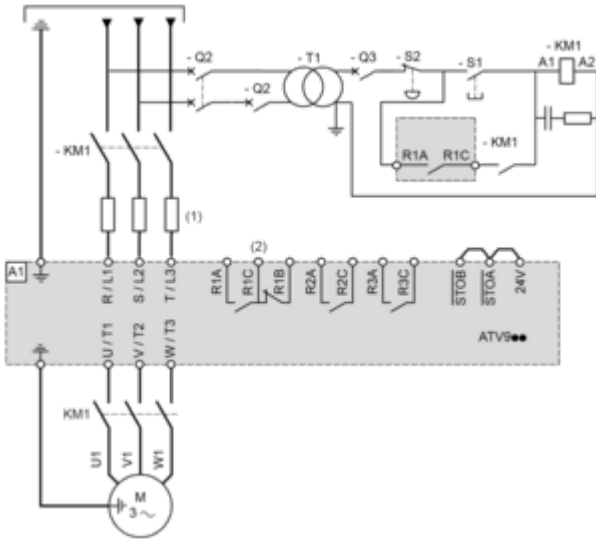

(1) Line choke if used

(2) Use relay R1 set to operating state Fault to switch Off the product once an error is detected.

A1 : Drive

KM1 : Contactor

Control Block Wiring Diagram

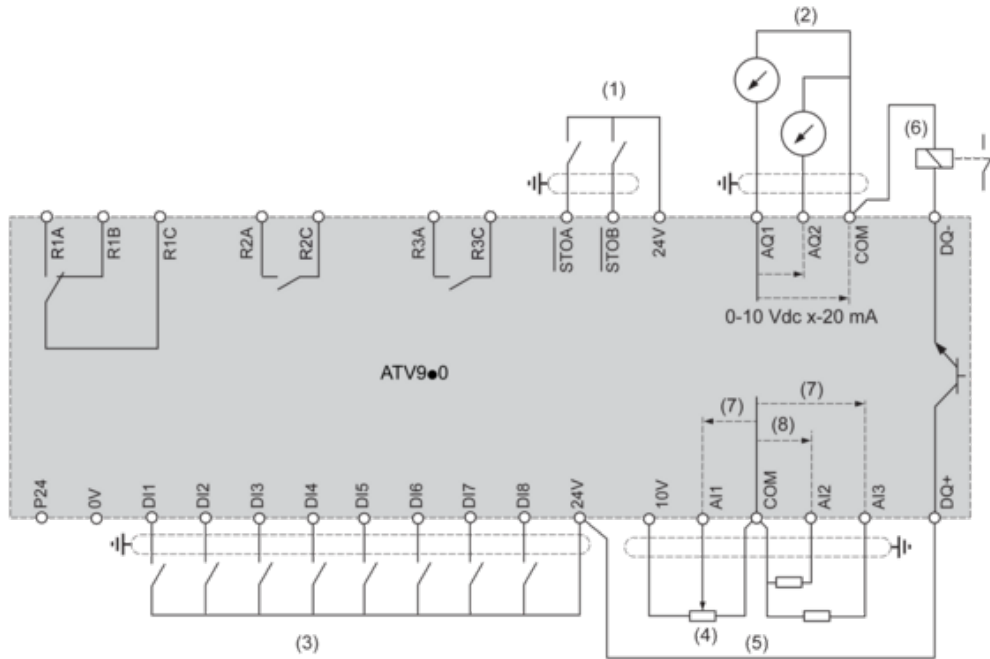

- (1) Safe Torque Off
 - (2) Analog Output
 - (3) Digital Input
 - (4) Reference potentiometer
 - (5) Analog Input
 - (6) Digital Output
 - (7) 0-10 Vdc, x-20 mA
 - (8) 0-10 Vdc, -10 Vdc...+10 Vdc
- R1A, R1B, R1C** : Fault relay
R2A, R2C : Sequence relay
R3A, R3C : Sequence relay

Sensor Connection

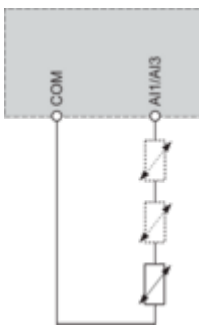

It is possible to connect either 1 or 3 sensors on terminals AI1 or AI3

Sink / Source Switch Configuration

The switch is used to adapt the operation of the logic inputs to the technology of the programmable controller outputs.

- Set the switch to Source (factory setting) if using PLC outputs with PNP transistors.
- Set the switch to Ext if using PLC outputs with NPN transistors.

Switch Set to SRC (Source) Position Using the Output Power Supply for the Digital Inputs

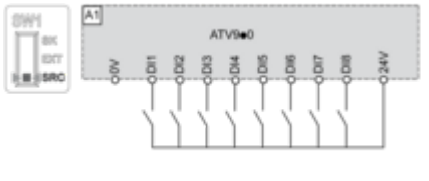

Switch Set to SRC (Source) Position and Use of an External Power Supply for the DIs

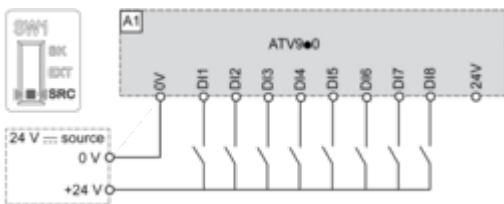

Switch Set to SK (Sink) Position Using the Output Power Supply for the Digital Inputs

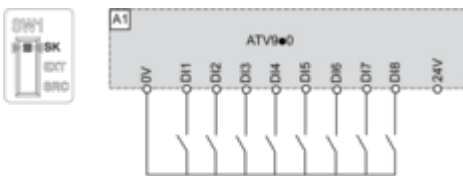

Switch Set to EXT Position Using an External Power Supply for the DIs

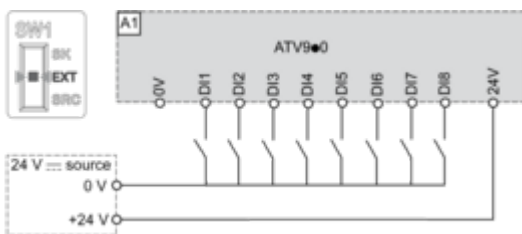

Performance Curves

Derating Curves

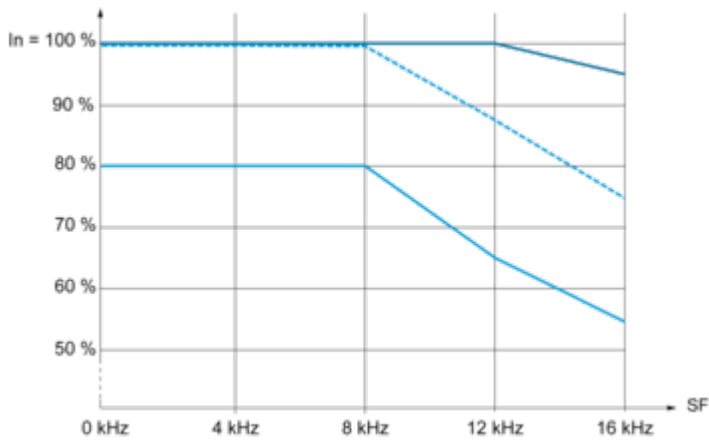

- 40 °C (104 °F) - Mounting type A, B and C
- - - 50 °C (122 °F) - Mounting type A, B and C
- 60 °C (140 °F) - Mounting type B and C

In : Nominal Drive Current

SF : Switching Frequency

Technical Illustration

Dimensions

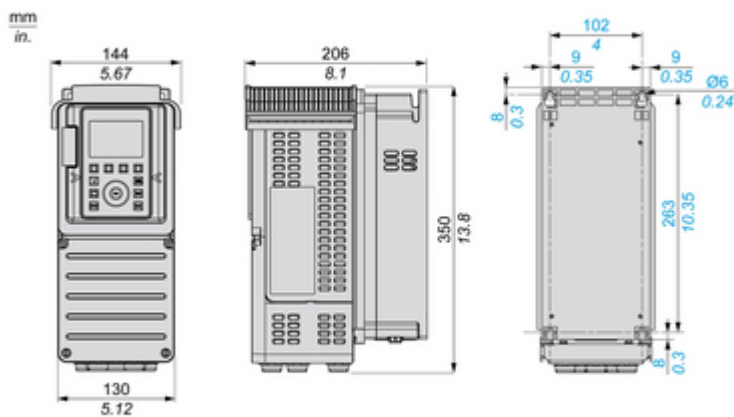

Image of product / Alternate images

Alternative





