



solid-state time-delayed auxiliary switch, off delayed, with control signal, relay 1 NC + 1 NO, time range 0.05-100 s, 24-240 V AC/DC, 50/60 Hz, varistor for attenuation of the contactor coils integrated, screw terminal, can be snapped onto the front on contactors 3RT20 and contactor relays 3RH2

product brand name	SIRIUS
product designation	Solid-state time-delay auxiliary switch
product type designation	3RA28
General technical data	
size of contactor can be combined company-specific	S00, S0, S2, S3
product component semi-conductor output	No
product extension required remote control	No
product extension optional remote control	No
insulation voltage for overvoltage category III according to IEC 60664 with degree of pollution 3 rated value	300 V
test voltage for isolation test	1.5 kV
degree of pollution	3
surge voltage resistance rated value	4 kV
test voltage for surge voltage test	4 800 V
consumed current	
• at 24 V	24 mA
• at 240 V	7 mA
protection class IP of the terminal	IP20
shock resistance according to IEC 60068-2-27	15 g / 11 ms
vibration resistance according to IEC 60068-2-6	10 ... 59 Hz: 0.35 mm, 60 ... 150 Hz: 2 g
mechanical service life (operating cycles) typical	10 000 000
mechanical service life (operating cycles)	
• with contactor 3R.2 of frame size S00	10 000 000
• with contactor 3R.2 of frame size S0	10 000 000
• with contactor 3R.2 of frame size S2	10 000 000
• with contactor 3R.2 of frame size S3	10 000 000
electrical endurance (operating cycles) at AC-15 at 230 V typical	100 000
electrical endurance (operating cycles)	
• with contactor 3R.2 of frame size S00	100 000
• with contactor 3R.2 of frame size S0	100 000
• with contactor 3R.2 of frame size S2	100 000
• with contactor 3R.2 of frame size S3	100 000
adjustable time	0.05 ... 100 s
relative setting accuracy relating to full-scale value	15 %
minimum ON period	35 ms
recovery time	150 ms
reference code according to IEC 81346-2	K
active principle	electronic
relative repeat accuracy	1 %

influence of the surrounding temperature	±1 %
power supply influence	±1 %
Substance Prohibition (Date)	10/01/2009
SVHC substance name	Lead CAS-No. 7439-92-1 Lead monoxide (lead oxide) CAS-No. 1317-36-8 2-methyl-1-(4-methylthiophenyl)-2-morpholinopropan-1-one CAS-No. 71868-10-5 Melamine CAS-No. 108-78-1 6,6'-di-tert-butyl-2,2'-methylenedi-p-cresol CAS-No. 119-47-1
Net Weight	95 g
Product Function	
product function star-delta circuit	No
Control circuit/ Control	
type of voltage of the control supply voltage	AC/DC
control supply voltage 1 at AC	
• at 50 Hz	24 ... 240 V
• at 60 Hz	24 ... 240 V
control supply voltage frequency 1	50 ... 60 Hz
control supply voltage 1 at DC	24 ... 240 V
operating range factor control supply voltage rated value at DC	
• initial value	0.85
• full-scale value	1.1
operating range factor control supply voltage rated value at AC at 50 Hz	
• initial value	0.85
• full-scale value	1.1
operating range factor control supply voltage rated value at AC at 60 Hz	
• initial value	0.85
• full-scale value	1.1
design of the surge suppressor	with varistor
Switching Function	
switching function	
• ON-delay	No
• ON-delay/instantaneous contact	No
• passing make contact	No
• passing make contact/instantaneous contact	No
• OFF delay	Yes
switching function	
• flashing symmetrically with interval start/instantaneous	No
• flashing symmetrically with interval start	No
• flashing symmetrically with pulse start/instantaneous	No
• flashing symmetrically with pulse start	No
• flashing asymmetrically with interval start	No
• flashing asymmetrically with pulse start	No
switching function	
• constant clock cycle with pulse start	No
• constant clock cycle with interval start	No
switching function	
• variably clocked with pulse start	No
• variably clocked with interval start	No
switching function	
• star-delta circuit with delay time	No
• star-delta circuit	No
switching function with control signal	
• additive ON-delay	No
• passing break contact	No
• passing break contact/instantaneous	No
• OFF delay	Yes
• OFF delay/instantaneous	No

• pulse delayed	No
• pulse delayed/instantaneous	No
• pulse-shaping	No
• pulse-shaping/instantaneous	No
• additive ON-delay/instantaneous	No
• ON-delay/OFF-delay	No
• ON-delay/OFF-delay/instantaneous	No
• passing make contact	No
• passing make contact/instantaneous contact	No
switching function of interval relay with control signal	
• retrotriggerable with deactivated control signal/instantaneous contact	No
• retrotriggerable with switched-on control signal	No
• retrotriggerable with switched-on control signal/instantaneous contact	No
• retriggerable with deactivated control signal	No
design of the control terminal non-floating	Yes
Short-circuit protection	
design of the fuse link for short-circuit protection of the auxiliary switch required	fuse gL/gG: 4 A
Auxiliary circuit	
material of switching contacts	AgNi
number of NC contacts	
• delayed switching	1
number of NO contacts	
• delayed switching	1
operational current of auxiliary contacts at AC-15	
• maximum	3 A
• at 24 V	3 A
• at 250 V	3 A
operational current of auxiliary contacts as NC contact at AC-15	
• at 24 V	3 A
• at 250 V	3 A
operational current of auxiliary contacts as NO contact at AC-15	
• at 24 V	3 A
• at 250 V	3 A
operational current of auxiliary contacts at DC-13	1 ... 0.1
operational current of auxiliary contacts at DC-13	
• at 24 V	1 A
• at 125 V	0.2 A
• at 250 V	0.1 A
operating frequency with 3RT2 contactor maximum	2 500 1/h
contact rating of auxiliary contacts according to UL	B300 / R300
Main circuit	
type of voltage	AC/DC
Inputs/ Outputs	
product function	
• at the relay outputs switchover delayed/without delay	No
• non-volatile	No
Electromagnetic compatibility	
EMC immunity according to IEC 61812-1	Environment A (industrial area)
conducted interference	
• due to burst according to IEC 61000-4-4	2 kV network connection / 1 kV control connection
• due to conductor-earth surge according to IEC 61000-4-5	2 kV
• due to conductor-conductor surge according to IEC 61000-4-5	1 kV
field-based interference according to IEC 61000-4-3	10 V/m
electrostatic discharge according to IEC 61000-4-2	8 kV

Safety related data	
category according to EN 954-1	none
Electrical Safety	
protection class IP on the front according to IEC 60529	IP20
touch protection on the front according to IEC 60529	finger-safe, for vertical contact from the front
type of insulation	Basic insulation
Connections/ Terminals	
product component removable terminal for auxiliary and control circuit	Yes
type of electrical connection	
<ul style="list-style-type: none"> for auxiliary and control circuit 	screw-type terminals
type of connectable conductor cross-sections	
<ul style="list-style-type: none"> solid 	0.5 ... 4 mm ² , 2x (0.5 ... 2.5 mm ²)
<ul style="list-style-type: none"> finely stranded with core end processing 	1x (0.5 ... 2.5 mm ²), 2x (0.5 ... 1.5 mm ²)
<ul style="list-style-type: none"> for AWG cables solid 	2x (20 ... 14)
<ul style="list-style-type: none"> for AWG cables stranded 	2x (20 ... 14)
connectable conductor cross-section	
<ul style="list-style-type: none"> solid 	0.5 ... 4 mm ²
<ul style="list-style-type: none"> finely stranded with core end processing 	0.5 ... 2.5 mm ²
<ul style="list-style-type: none"> finely stranded without core end processing 	0.25 ... 1.5 mm ²
AWG number as coded connectable conductor cross section	
<ul style="list-style-type: none"> solid 	20 ... 14
<ul style="list-style-type: none"> stranded 	20 ... 14
Installation/ mounting/ dimensions	
mounting position	any (like contactor)
fastening method	clip-on
height	38 mm
width	45 mm
depth	74 mm
required spacing	
<ul style="list-style-type: none"> with side-by-side mounting <ul style="list-style-type: none"> forwards backwards upwards downwards at the side for grounded parts <ul style="list-style-type: none"> forwards backwards upwards at the side downwards for live parts <ul style="list-style-type: none"> forwards backwards upwards downwards at the side 	0 mm 0 mm 0 mm 0 mm 0 mm 0 mm 0 mm 0 mm 0 mm 0 mm 0 mm 0 mm 0 mm 0 mm 0 mm
Ambient conditions	
installation altitude at height above sea level maximum	2 000 m
ambient temperature	
<ul style="list-style-type: none"> during operation 	-25 ... +60 °C
<ul style="list-style-type: none"> during storage 	-40 ... +85 °C
<ul style="list-style-type: none"> during transport 	-40 ... +85 °C
relative humidity during operation	0 ... 95 %
Approvals Certificates	
Environment	General Product Approval
	Maritime application

[Environmental Con-
firmations](#)



Maritime application



other

[Confirmation](#)

Further information

Information on the packaging

<https://support.industry.siemens.com/cs/ww/en/view/109813875>

Information for data generation and storage

<https://support.industry.siemens.com/cs/ww/en/view/109995012>

Information- and Downloadcenter (Catalogs, Brochures,...)

<https://www.siemens.com/ic10>

Industry Mall (Online ordering system)

<https://mall.industry.siemens.com/mall/en/en/Catalog/product?mlfb=3RA2814-1FW10>

Cax online generator

<https://support.automation.siemens.com/WW/CAXorder/default.aspx?lang=en&mlfb=3RA2814-1FW10>

Service&Support (Manuals, Certificates, Characteristics, FAQs,...)

<https://support.industry.siemens.com/cs/ww/en/ps/3RA2814-1FW10>

Image database (product images, 2D dimension drawings, 3D models, device circuit diagrams, EPLAN macros, ...)

https://www.automation.siemens.com/bilddb/cax_de.aspx?mlfb=3RA2814-1FW10&lang=en

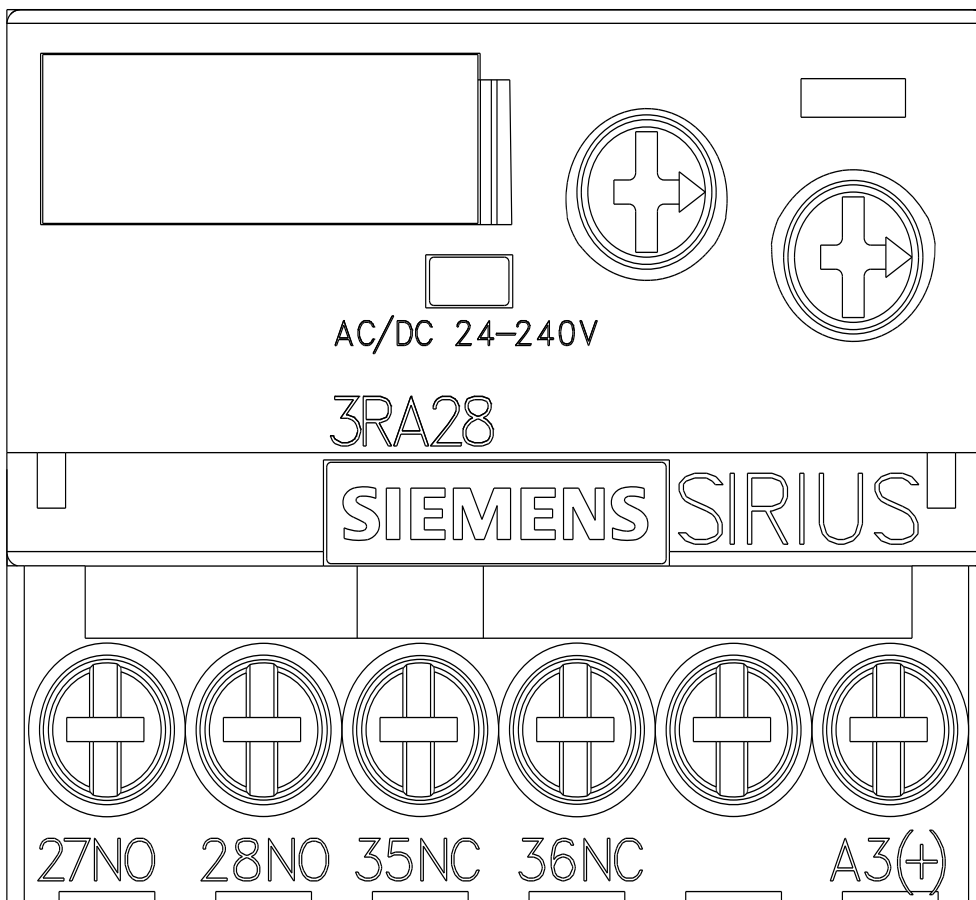
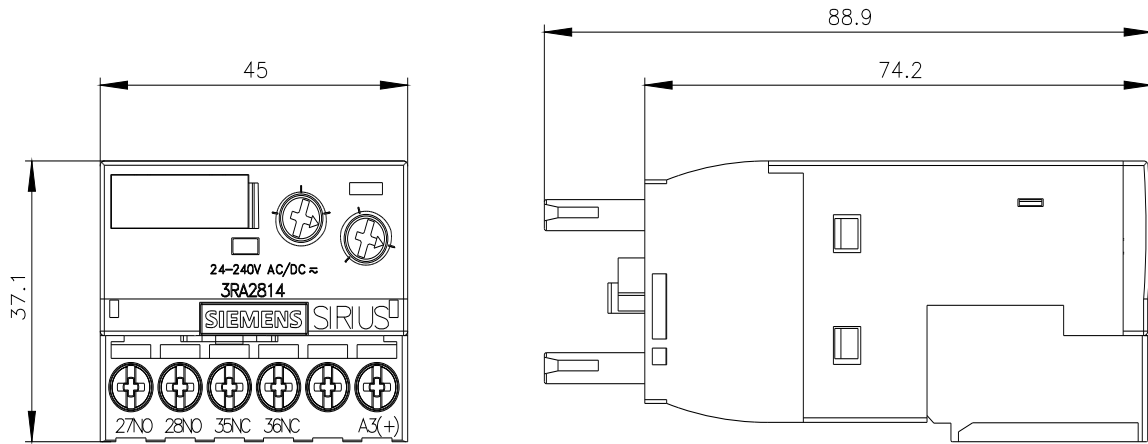

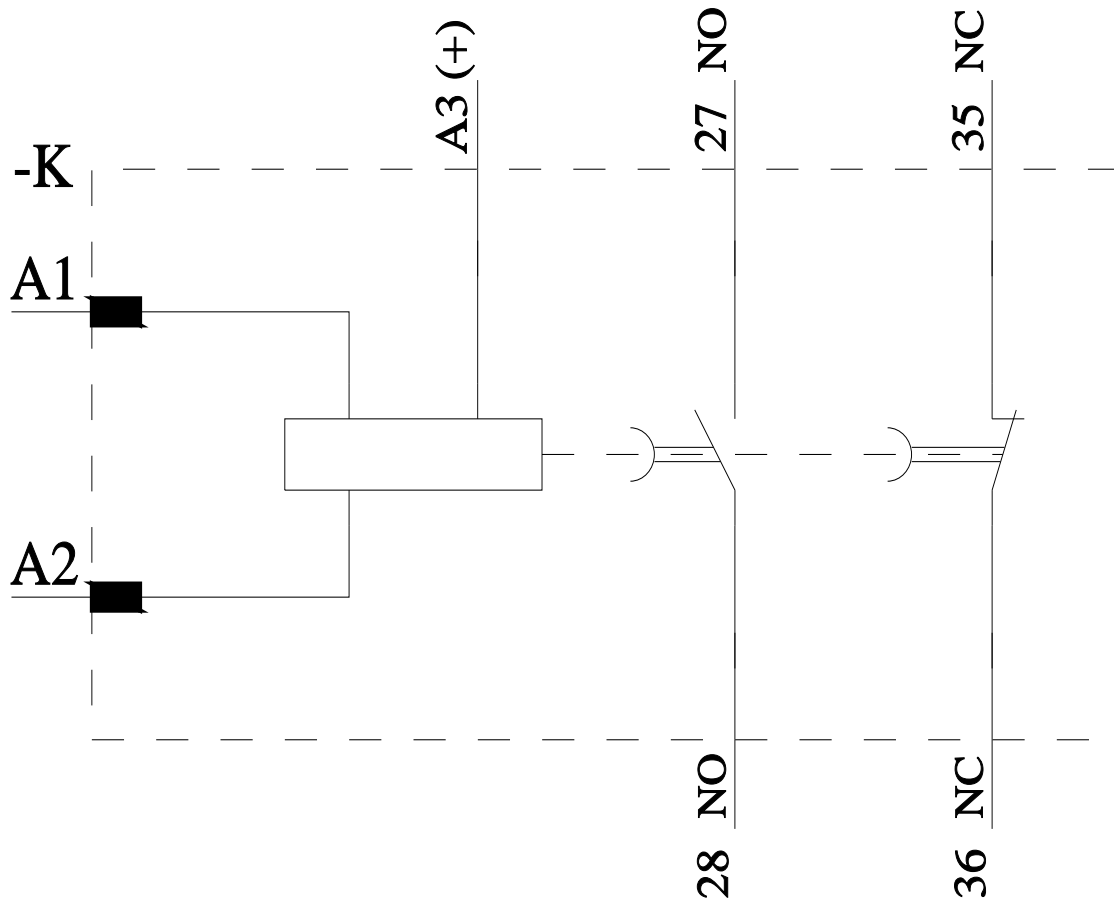
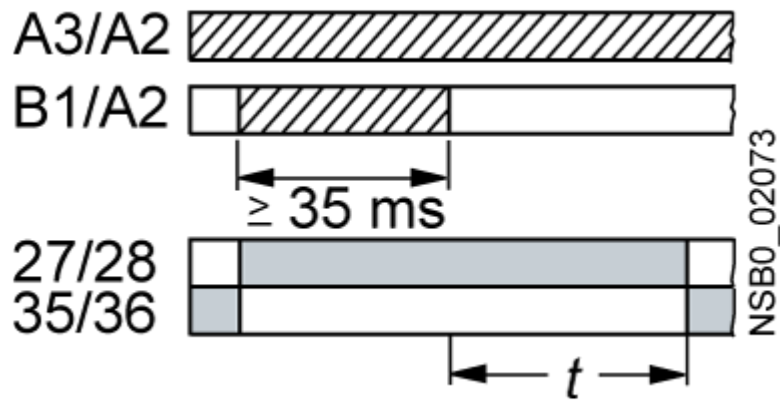

last modified:

4/4/2026