



SENTRON, Fuse switch disconnecter 3NP1, 3-pole, NH000, 160 A, for Rittal busbar system 60 mm, Box terminal, Fuse monitoring: electronic EFM10, Cover level 32/70 mm

Model	
product designation	Fuse switch disconnecter
busbar design	busbar thickness 5 or 10 mm
design of the safety monitoring	electronic EFM 10
design of the load switch strip form	No
type of the driving mechanism motor drive	No
General technical data	
number of poles	3
type of device	For Rittal 60 mm busbar system
size of disconnecting link	000
size of fuse link	NH000
let-through current with closed switch maximum	15 kA
mechanical service life (operating cycles) typical	2 000
I ² t value with closed switch maximum	223 kA ² ·s
power factor	
• at AC-22 B	0.65
• at AC-23 B	0.45
• with capacitive load	-0.25
fuse system	LV HRC fuse
degree of pollution	2
Voltage	
insulation voltage	
• rated value	690 V
• with degree of pollution 3 at AC rated value	690 V
• with degree of pollution 2 at AC rated value	1 000 V
power factor at AC-21 B	0.95
surge voltage resistance rated value	8 kV
• operational current	
— at 35 °C rated value	160 A
— at 40 °C rated value	150 A
— at 45 °C rated value	140 A
— at 50 °C rated value	130 A
— at 55 °C rated value	120 A
• operational current	
— at AC-21 B at 240 V rated value	160 A
— at AC-21 B at 400 V rated value	160 A
— at AC-21 B at 500 V rated value	160 A
— at AC-21 B at 690 V rated value	160 A

— at AC-22 B at 240 V rated value	160 A
— at AC-22 B at 400 V rated value	160 A
— at AC-22 B at 500 V rated value	125 A
— at AC-22 B at 690 V rated value	50 A
— at AC-23 B at 690 V rated value	25 A
— at AC-23 B at 500 V rated value	40 A
— at AC-23 B at 400 V rated value	160 A
— at AC-23 B at 240 V rated value	160 A
let-through current with high-speed activation maximum permissible	10 kA
operating voltage	
• at AC rated value minimum	230 V
• at AC rated value maximum	690 V
Protection class	
protection class IP	
• with closed switch with cover or cable lug cover	IP40
• with closed switch without cover or cable lug cover	IP30
• open	IP20
Dissipation	
power loss [W]	
• with conventional rated thermal current without fuse per pole	5 W
• with conventional rated thermal current without fuse per device	15 W
• for rated value of the current at AC in hot operating state per pole	5.7 W
• of the fuse per fuse maximum	9 W
Main circuit	
operational current	
• rated value	125 A
• with capacitive load at 400 V rated value	72 A
• with capacitive load at 500 V rated value	55 A
Auxiliary circuit	
number of CO contacts for auxiliary contacts	0
number of NC contacts for auxiliary contacts	0
number of NO contacts for auxiliary contacts	0
Suitability	
suitability for use main switch	No
suitability for use switch disconnecter	Yes
suitability for use EMERGENCY OFF switch	No
suitability for use safety switch	Yes
suitability for use maintenance/repair switch	Yes
Product details	
product function phase failure monitoring	No
product component	
• undervoltage release	No
• undervoltage release with leading contact	No
product feature sealable	Yes
product extension auxiliary switch	Yes
product extension optional locking capability	Yes
product extension optional phase failure monitoring	Yes
product extension optional voltage trigger	No
product extension optional overvoltage protection monitoring	Yes
Product function	
product function overvoltage protection monitoring	No
Short circuit	
conditional short-circuit current (I_q)	
• at AC at 240 V with high-speed activation rated value	80 kA
• at AC at 500 V with high-speed activation rated value	80 kA

• at AC at 690 V with high-speed activation rated value	50 kA
• with closed switch at AC at 240 V rated value	120 kA
• with closed switch at AC at 500 V rated value	120 kA
• with closed switch at AC at 690 V rated value	100 kA

Connections

arrangement of electrical connectors for main current circuit	other
connectable conductor cross-section for main contacts	
• solid or stranded minimum	1.5 mm ²
• solid or stranded maximum	50 mm ²
• finely stranded with core end processing minimum	1.5 mm ²
• finely stranded with core end processing maximum	35 mm ²
• stranded minimum	1.5 mm ²
• stranded maximum	50 mm ²
tightening torque with screw-type terminals	
• minimum	3.5 N·m
• maximum	4 N·m
type of connectable conductor cross-sections of the laminated conductors maximum	8 x 8 mm
type of connection technology	Box terminal

Mechanical Design

height	210.4 mm
width	88.8 mm
width of the busbar	
• minimum	12 mm
• maximum	30 mm
depth	140.9 mm
fastening method	busbar
fastening method	
• floor mounting	No
• rail mounting	Yes
mounting position	horizontal/vertical
busbar center-to-center spacing	60 mm
Net Weight	1.023 kg

Environmental conditions

ambient temperature during operation	
• minimum	-25 °C
• maximum	55 °C
ambient temperature during storage	
• minimum	-50 °C
• maximum	80 °C

Certificates

reference code according to IEC 81346-2	Q
--	---

Approvals Certificates

Environment	General Product Approval
--------------------	---------------------------------

[Environmental Con-
firmations](#)

[Environmental Con-
firmations](#)



[Miscellaneous](#)



Maritime application



Further information

Information on the packaging

<https://support.industry.siemens.com/cs/ww/en/view/109813875>

Information for data generation and storage

<https://support.industry.siemens.com/cs/ww/en/view/109995012>

Information- and Downloadcenter (Catalogs, Brochures,...)

<https://www.siemens.com/lowvoltage/catalogs>

Industry Mall (Online ordering system)

<https://mall.industry.siemens.com/mall/en/en/Catalog/product?mfb=3NP1123-1JC22>

Service&Support (Manuals, Certificates, Characteristics, FAQs,...)

<https://support.industry.siemens.com/cs/ww/en/ps/3NP1123-1JC22>

Image database (product images, 2D dimension drawings, 3D models, device circuit diagrams, ...)

https://www.automation.siemens.com/bilddb/cax_en.aspx?mfb=3NP1123-1JC22

CAX-Online-Generator

<https://www.siemens.com/cax>

Tender specifications

<https://www.siemens.com/specifications>

Characteristic curves

https://curves.simaris.siemens.com/curves/<mmp_prod_noCOMP='HAUPT'></mmp_prod_no>

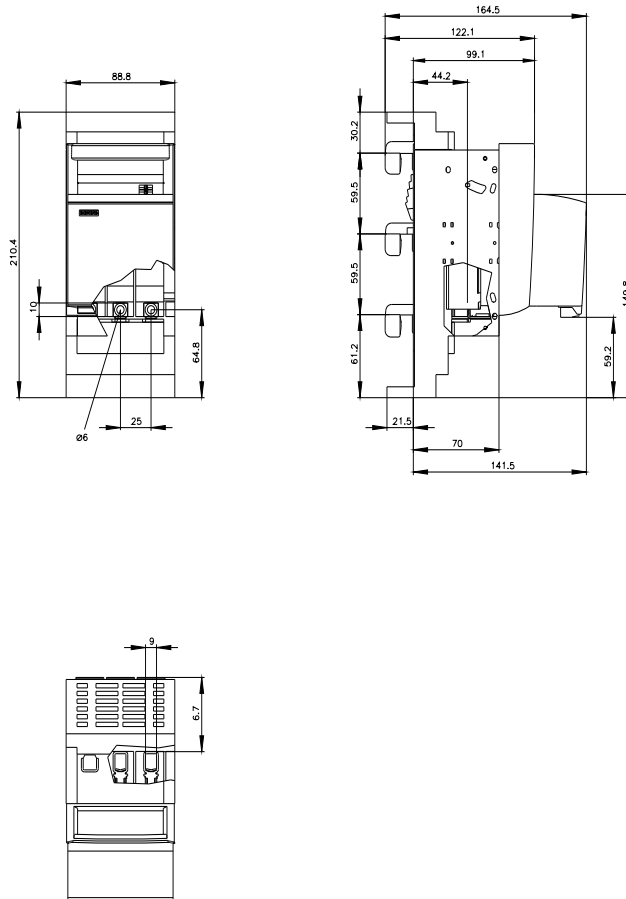

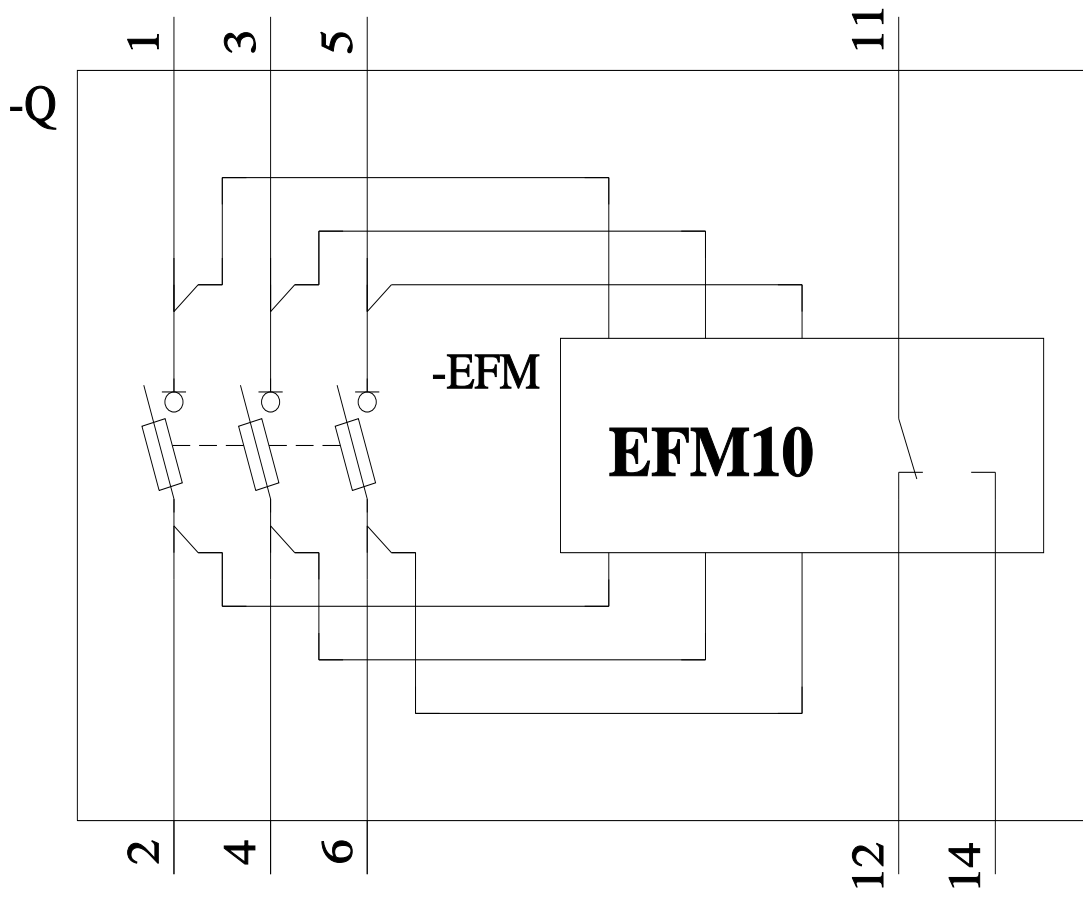

last modified:

3/29/2026 

