

switch disconnecter with fuse 800 A, frame size 5, 3-pole for LV HRC fuse size 2 and 3 front operating mechanism left complete unit with direct operating mechanism flat connector without fuses

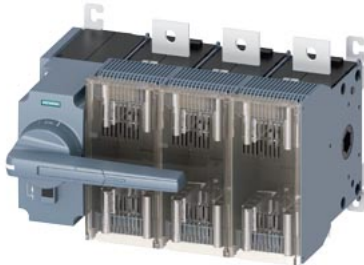

Model	
product brand name	SENTRON
product designation	3KF switch disconnecter with fuses
design of the product	3KF switch disconnecter with fuses
product version	3KF NH
design of the actuating element	manual operating mechanism
design of handle	Direct operating mechanism, gray
direction of actuation	from the front
type of the driving mechanism motor drive	No
number of poles	3
size of disconnecting link	3 and 2
size of switch disconnecter	5
size of fuse link	NH2, NH3
mechanical service life (operating cycles) typical	6 000
electrical endurance (operating cycles)	
• at AC-23 A at 440 V	1 500
• at AC-23 A at 690 V	1 000
• at DC-23 A at 440 V	500
I ² t value	
• with closed switch for combination switch + fuse at 500 V maximum	4 100 000 A ² ·s
• with closed switch for combination switch + fuse at 400 V maximum	4 100 000 A ² ·s
• with closed switch at 690 V for combination switch + gG fuse maximum	2 050 000 A ² ·s
• of the fuse at 500 V maximum permissible	10 400 000 A ² ·s
• of the gG fuse at 690 V maximum permissible	7 000 000 A ² ·s
• of the aM fuse at 690 V maximum permissible	7 000 000 A ² ·s
position of the switch operating mechanism	left
fuse system	LV HRC fuse
overvoltage category	IV
operating voltage with current paths in series	
• with degree of pollution 2 at DC rated value	440 / 3
• with degree of pollution 3 at DC rated value	440 / 3
surge voltage resistance rated value	12 kV
Supply voltage	
operating voltage at AC rated value maximum	690 V
Protection class	
protection class IP	IP00
protection class IP	

<ul style="list-style-type: none"> with closed switch with cover or cable lug cover 	IP20
<ul style="list-style-type: none"> on the front 	IP00
Dissipation	
power loss [W]	
<ul style="list-style-type: none"> with conventional rated thermal current per pole 	50 W
<ul style="list-style-type: none"> with conventional rated thermal current per device 	150 W
<ul style="list-style-type: none"> with conventional rated thermal current without fuse per pole 	50 W
<ul style="list-style-type: none"> with conventional rated thermal current without fuse per device 	150 W
<ul style="list-style-type: none"> for rated value of the current at AC in hot operating state per pole 	50 W
<ul style="list-style-type: none"> of the fuse per fuse maximum 	60 W
Main circuit	
operating power at AC-23 A at 500 V rated value	560 kW
operational current rated value	800 A
Auxiliary circuit	
number of connected NC contacts for auxiliary contacts	0
number of connected NO contacts for auxiliary contacts	0
number of connected CO contacts for auxiliary contacts	0
number of CO contacts for auxiliary contacts	0
number of NC contacts for auxiliary contacts	8
number of NO contacts for auxiliary contacts	8
suitability for use main switch	Yes
suitability for use switch disconnecter	Yes
suitability for use EMERGENCY OFF switch	No
suitability for use safety switch	Yes
suitability for use maintenance/repair switch	Yes
product feature interlock	Yes
product function phase failure monitoring	No
product component	
<ul style="list-style-type: none"> voltage trigger 	No
<ul style="list-style-type: none"> undervoltage release 	No
<ul style="list-style-type: none"> undervoltage release with leading contact 	No
product feature sealable	Yes
product extension auxiliary switch	Yes
product extension optional locking capability	No
product extension optional motor drive	No
product extension optional fuse monitoring	Yes
product function	
<ul style="list-style-type: none"> fuse monitoring 	No
<ul style="list-style-type: none"> overvoltage protection monitoring 	No
Short circuit	
short-circuit current making capacity (I _{cm}) for switch disconnecter at 690 V AC/440 V DC without fuse link rated value minimum	44 kA
conditional short-circuit current with line-side fuse protection	
<ul style="list-style-type: none"> at 500 V by gG fuse rated value 	100 kA
<ul style="list-style-type: none"> at 690 V by gG fuse rated value 	80 kA
Connections	
arrangement of electrical connectors for main current circuit	Top and bottom
tightening torque with screw-type terminals	
<ul style="list-style-type: none"> minimum 	50 N·m
<ul style="list-style-type: none"> maximum 	75 N·m
type of connectable conductor cross-sections for aluminum conductor stranded with lug	1x (25 ... 300 mm ²), 2x (25 ... 300 mm ²)
type of connectable conductor cross-sections	
<ul style="list-style-type: none"> for copper busbar 	2x (50 x 5 mm ²)
type of connectable conductor cross-sections for copper conductor	

<ul style="list-style-type: none"> • stranded with lug according to DIN 46234 	1x (25 ... 240 mm ²), 2x (25 ... 240 mm ²)
<ul style="list-style-type: none"> • stranded with lug according to DIN 46235 	1x (25 ... 300 mm ²), 2x (25 ... 300 mm ²)
type of electrical connection for main current circuit	flat connector

Mechanical Design

height	270 mm
width	395 mm
depth	335 mm
fastening method	floor mounting
fastening method	
<ul style="list-style-type: none"> • 4-hole front mounting 	No
<ul style="list-style-type: none"> • front mounting with central attachment 	No
<ul style="list-style-type: none"> • rail mounting 	No
mounting position	any
Net Weight	18 kg

Environmental conditions

ambient temperature during operation	
<ul style="list-style-type: none"> • minimum 	-25 °C
<ul style="list-style-type: none"> • maximum 	70 °C
ambient temperature during storage	
<ul style="list-style-type: none"> • minimum 	-50 °C
<ul style="list-style-type: none"> • maximum 	80 °C

Approvals Certificates

Environment	General Product Approval
--------------------	---------------------------------

[Environmental Con-
firmations](#)

[Environmental Con-
firmations](#)



[Miscellaneous](#)



Maritime application



Further information

Information on the packaging

<https://support.industry.siemens.com/cs/ww/en/view/109813875>

Information for data generation and storage

<https://support.industry.siemens.com/cs/ww/en/view/109995012>

Information- and Downloadcenter (Catalogs, Brochures,...)

<https://www.siemens.com/lowvoltage/catalogs>

Industry Mall (Online ordering system)

<https://mall.industry.siemens.com/mall/en/en/Catalog/product?mlfb=3KF5380-2LF11>

Service&Support (Manuals, Certificates, Characteristics, FAQs,...)

<https://support.industry.siemens.com/cs/ww/en/ps/3KF5380-2LF11>

Image database (product images, 2D dimension drawings, 3D models, device circuit diagrams, ...)

https://www.automation.siemens.com/bilddb/cax_en.aspx?mlfb=3KF5380-2LF11

CAX-Online-Generator

<https://www.siemens.com/cax>

Tender specifications

<https://www.siemens.com/specifications>

Characteristic curves

[https://curves.simaris.siemens.com/curves/<mmp_prod_noCOMP="HAUPT"></mmp_prod_no>](https://curves.simaris.siemens.com/curves/<mmp_prod_noCOMP=)

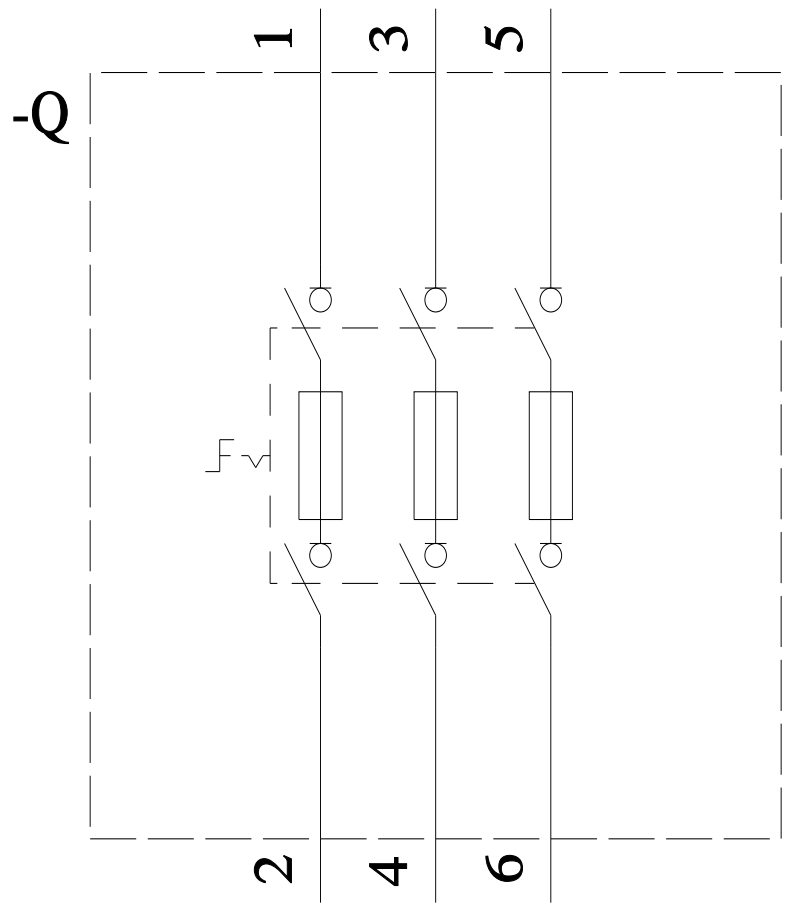
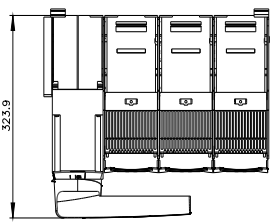
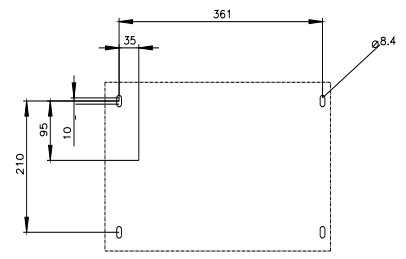
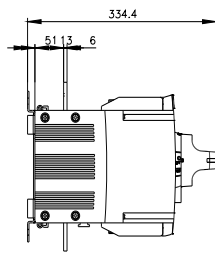
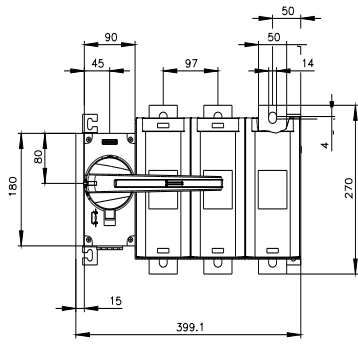



last modified:

4/3/2025

